

GP61X9

Cooker size	60x60 cm
N. of cavities with energy label	1
Cavity heat source	Electric
Hob type	Gas
Type of main oven	Thermo-ventilated
Cleaning system main oven	Pyrolytic
EAN code	8017709181789
Energy efficiency class	A



Aesthetics











Aesthetics	Classic	Display	electronic 5 buttons
Series	Concert	Colour of buttons	Black
Colour	Stainless steel	No. of controls	6
Finishing	Brushed	Serigraphy colour	Black
Design	Standard	Handle	Smeg Classic
Door	Full glass	Handle Colour	Brushed stainless steel
Upstand	Yes	Glass type	Stopsol
Type of pan stands	Cast Iron	Feet	Silver
Hob colour	Stainless steel	Storage compartment	Door
Command panel finish	Stainless steel	Logo	Embossed
Control knobs	Smeg Classic	Logo position	Facia below the oven
Controls colour	Stainless steel		

Programs / Functions

No. of cooking functions	9
--------------------------	---

Traditional cooking functions

 Static	 Fan assisted	 Circulaire
 Turbo (circulaire + bottom + upper + fan)	 ECO	 Small grill
 Large grill	 Fan grill (large)	 Fan assisted base









Cleaning functions

 Pyrolytic
--

Hob technical features

			
Total no. of cook zones	4		
Front left - Gas - UR	3.50 kW		
Rear left - Gas - Semi Rapid	1.75 kW		
Rear right - Gas - Semi Rapid	1.75 kW		
Front right - Gas - AUX	1.00 kW		
Type of gas burners	Standard	Gas safety valves	Yes
Automatic electronic ignition	Yes	Burner caps	Matt black enamelled

Main Oven Technical Features

									
No. of lights	2	No. of thermo-reflective door glasses	3						
Net volume of the cavity	70 litres	Safety Thermostat	Yes						
Gross volume, 1st cavity	79 l	Heating suspended when door is opened	Yes						
Cavity material	Easy clean enamel	Cooling system	Tangential						
Shelf positions	5	Door Lock During Pyrolysis	Yes						
Type of shelves	Metal racks	Usable cavity space dimensions (HxWxD)	360X460X425 mm						
Light type	Halogen	Temperature control	Electro-mechanical						
Light power	40 W								
Cooking time setting	Start and Stop								
Light when oven door is open	Yes								

Removable door	Yes	Lower heating element power	1200 W
Full glass inner door	Yes	Upper heating element - Power	1000 W
Removable inner door	Yes	Grill element	1700 W
Total no. of door glasses	4	Large grill - Power	2700 W
		Circular heating element - Power	2000 W
		Grill type	Electric

Options Main Oven

Timer	Yes	Minimum Temperature	50 °C
End of cooking acoustic alarm	Yes	Maximum temperature	280 °C

Accessories included for Main Oven & Hob



Rack with back and side stop	2	Grill mesh	1
40mm deep tray	1	Telescopic Guide rails, partial Extraction	1

Electrical Connection

Nominal power	3000 W	Frequency	50/60 Hz
Current	13 A	Power supply cable length	120 cm
Voltage	220-240 V	Terminal block	3 poles
Voltage 2 (V)	380-415 V		

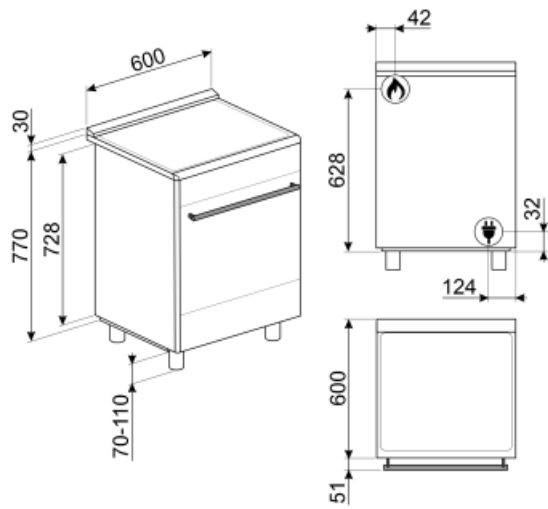

Not included accessories

AIRFRY

Air fryer rack AIRFRY . Ideal for recreating traditional frying in the oven, but with fewer calories and less fat. It allows you to cook quickly and simply dishes such as French fries, fried vegetables and fish, ensuring perfect browning and crispiness.



GTP

Partially extractable telescopic guides (1 level) Extraction: 300 mm Material: Stainless steel AISI 430 polished



BNP608T

Teflon-coated tray, 8mm depth, to be placed on the grid



BG6090-1

Cast iron grill plate suitable for Concert cookers



PPX6090-1

Stainless steel Teppanyaki grill plate suitable for 90cm Concert cookers



BBQ

Double sided plate BBQ. Suitable for recreating succulent and crispy dishes in the oven with the typical taste of grilled cooking. The ribbed side is particularly suitable for meats and cheeses. The smooth side for fish, seafood and vegetables.



KITPAX

Height extension feet (950 mm), stainless steel, suitable for Master, Symphony and Concertcookers

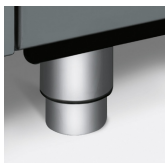

GTT

Totally extractable telescopic guides (1 level) Extraction: 433 mm Material: Stainless steel AISI 430 polished



SFLK1

Child lock



PRTX

Refractory pizza stone with handles. D=35cm Not suitable for microwave ovens. Suitable for gas ovens, to be put on the griddle.



PPR2

Refractory pizza stone without handles. Squared shaped stone: L42 x H1,8 x D37,5 cm. Suitable also for gas ovens, to be put on the griddle.



BN620-1

Enamelled tray, 20mm deep



KITPD

Height extension black feet (950 mm) for cookers



PALPZ

Pizza shovel with fold away handle width: 315mm length : 325mm



KITP60X9

Splashback, 90 cm, stainless steel, suitable for pyrolytic Concert cookers



BN640



















Enamelled tray, 40mm deep



SMOLD

Set of 7 silicone moulds for ice creams, ice lollies, pralines, ice cubes or to portion food. Usable from -60°C to +230°C

Symbols glossary

 <p>Heavy duty cast iron pan stands: for maximum stability and strength.</p>	 <p>Air cooling system: to ensure a safe surface temperatures.</p>
 <p>Quadruple glazed: Number of glazed doors.</p>	 <p>A: Product drying performance, measured from A+++ to D / G depending on the product family</p>
 <p>Enamel interior: The enamel interior of all Smeg ovens have a special antacid lining which helps keep the interior clean by reducing the amount of cooking grease adhering to it.</p>	 <p>Circogas: In gas ovens the fan distributes the heat quickly and evenly throughout the oven cavity, avoiding flavour transfer when cooking a number of different dishes at the same time. In electric ovens this combination completes cooking more quickly of foods that are ready on the surface, but that require more cooking inside, without further browning.</p>
 <p>Fan with upper and lower elements: The elements combined with the fan aim to provide more uniform heat, a similar method to conventional cooking, so pre-heat is required. Most suitable for items requiring slow cooking methods.</p>	 <p>Upper and lower element only: a traditional cooking method best suited for single items located in the centre of the oven. the top pf the oven will always be hottest. Ideal for roast, fruit cakes, bread etc.</p>
 <p>Circulaire: The combination of the fan and circular element around it gives a hot air cooking method. This provides many benefits including no preheat if cook time is more than 20 minutes, no flavour transfer when cooking different foods at the same time, less energy, and shorter cook times. Good for all types of food.</p>	 <p>ECO: The combination of the grill, fan and lower element is particularly suitable for cooking small quantities of food.</p>
 <p>Grill element: Using of grill gives excellent results when cooking meat of medium and small portions, especially when combined with a rotisserie (where possible). Also ideal for cooking sausages and bacon.</p>	 <p>Half grill: For rapid cooking and browning of foods. Best results can be obtained by using the top shelf for small items, the lower shelves for larger ones, such as chops or sausages. For half grill heat is generated only at the centre of the element, so is ideal for smaller quantities.</p>
 <p>Fan with grill element: The fan reduces the fierce heat from the grill, providing an excellent method of grilling various foods, chops, steaks, sausages etc. giving even browning and heat distribution, without drying out the food. The top two levels recommended for use, and the lower part of the oven can be used to keep items warm at the same time, an excellent facility when cooking a grilled breakfast. Half grill (centre portion only) is ideal for small quantities of food.</p>	 <p>Circulaire with upper and lower elements: The use of the fan with both elements allows food to be cooked quickly and effectively, ideal for large joints that require thorough cooking. It offers a similar result to rotisserie, moving the heat around the food, instead of moving the food itself, enabling any size or shape to be cooked.</p>
 <p>All glass inner door: All glass inner door, a single flat surface which is simple to keep clean.</p>	 <p>The inner door glass: can be removed with a few quick movements for cleaning.</p>
 <p>Side lights: Two opposing side lights increase visibility inside the oven.</p>	 <p>Pyrolytic: Pyrolytic cleaning cycles can be selected as necessary to automatically clean the oven interior.</p>



The oven cavity has 5 different cooking levels.



Telescopic rails: allow you to pull out the dish and check it without having to remove it from the oven entirely.



Ultra rapid burners: Powerful ultra rapid burners offer up to 5kw of power.



The capacity indicates the amount of usable space in the oven cavity in litres.